

UNIVERSITY OF ILLINOIS
AT URBANA-CHAMPAIGN

Phonon Transport Experiment

David G. Cahill

*Department of Materials Science and Engineering,
Materials Research Laboratory,
Department of Mechanical Sciences and Engineering*

University of Illinois at Urbana-Champaign



illinois.edu

Outline

- Take a step back and ask
 - What have we accomplished in the past 10 years?
 - What do we want to accomplish in the next 10 years?

Scientific Revolution Type I (Galison)

Acknowledge G. Whitesides Priestley award address, 2007, similar talk at APS Kavli "mesoscale physics" session 4 days ago.

- New techniques enable scientific revolutions
 - STM, then AFM, nucleated nanoscience
 - PCR made molecular genetics possible
 - NMR revolutionized organic synthesis
- Not in the same league but we have done well: TDTR, micro-fabricated test platforms, cantilever-based probes have completely changed what we can do.

TDTR, MEMS-based, scanning thermal probe

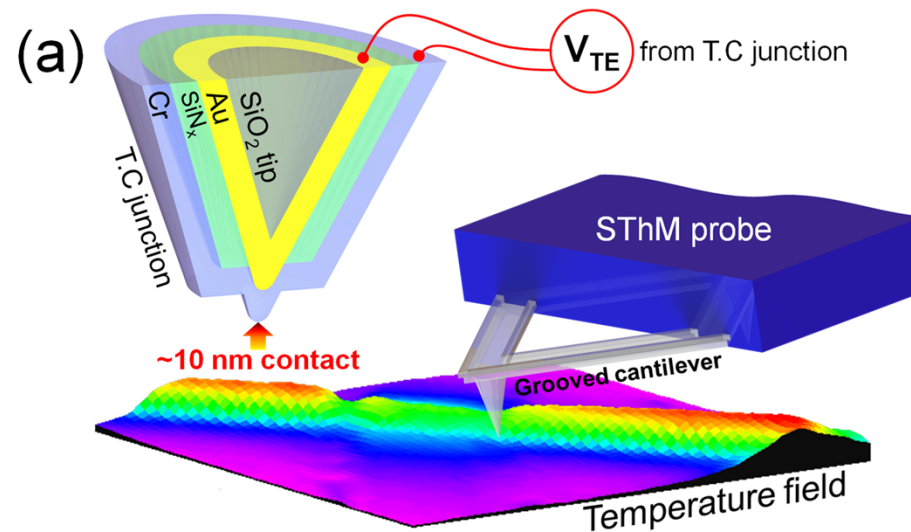
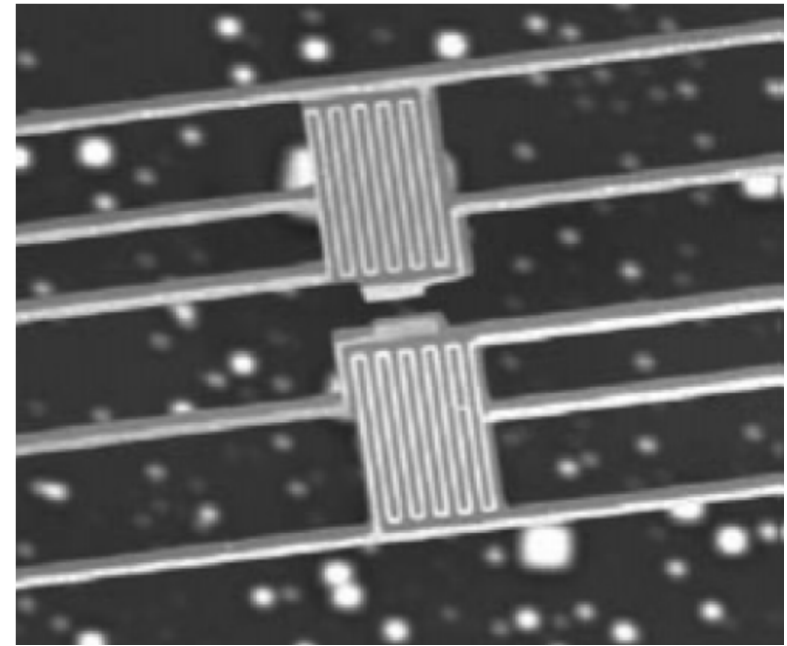
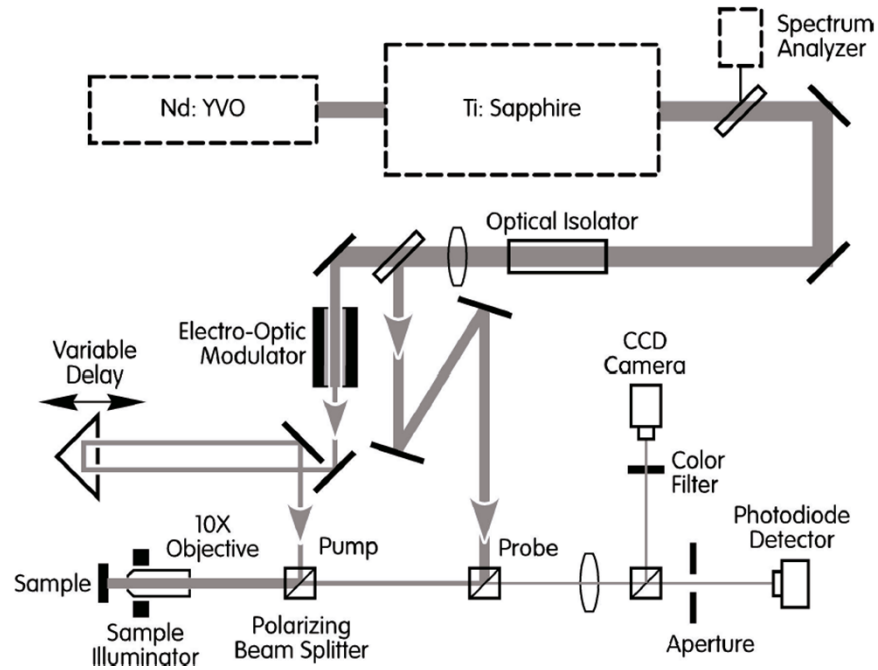

Scientific Revolution Type I

- Where are the next revolutionary tools?
 - Greater time/space/excitation-type/energy/momentum resolution?
- Certainly an important endeavor, but what theory or model do we want to probe or test?
- Fishing is often underappreciated but we need to fish in productive waters (more about that later).

Scientific Revolution Type II (Kuhn)

- Revolutions occur only when there is no way out; when current theories are incompatible with experimental evidence.
 - “Ultraviolet catastrophe”, Einstein heat capacity of solids, led to quantum mechanics
- Harder to declare success here. What theories or “conventional wisdoms” have been overturned?
 - New science of thermal phonons in roughened Si nanostructures, if proven correct.
 - Thermal conductivity below the amorphous limit.
 - Suspensions of spherical nanoparticles did not survive.

Scientific activities (Kuhn)

- “Normal science” is driven by “puzzles”.
 - This is what most of us do, most of the time: further develop an existing scientific paradigm.
 - Whitesides puts it more pointedly:
 - the answer is already known before the work starts;
 - the answer is not important;
 - the interest lies largely in the elegance of the solution.
 - But he goes on (to paraphrase Kuhn):
 - normal science is essential and required to select specific scientific puzzles for the intense cultivation that makes clear the fundamental limitations of science and that occasionally leads to scientific revolution.

Compare clean interface with a layer of CVD graphene inserted at the interface

- Clean interface has the weak pressure dependence expected from diffuse-mismatch (DMM) calculations.
- Insert graphene: low conductance and strong pressure dependence.
- At $P > 8$ GPa, “weak” interface becomes “strong” and conductance is high.

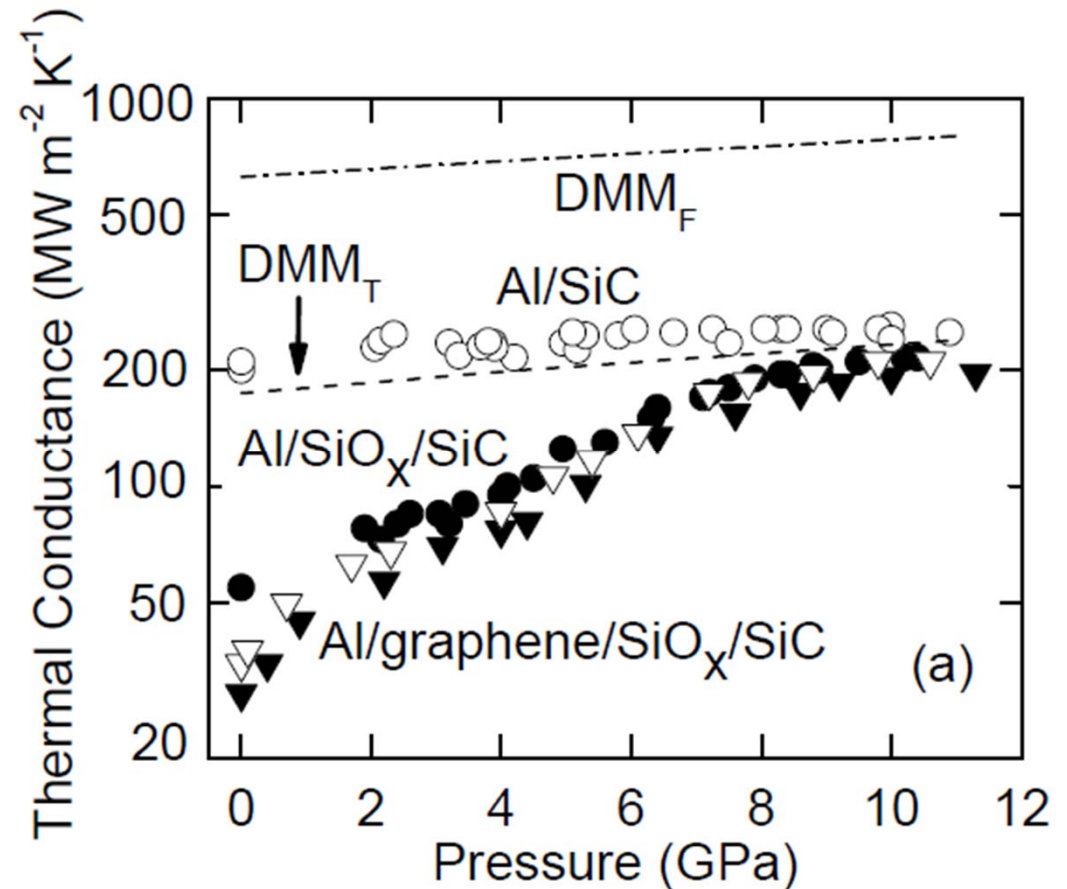

Scientific activities (Kuhn)

- Scientific “discovery” is driven by “problems”.
 - Whitesides’ take on this:
 - larger scale questions in which the answer does matter;
 - in which the strategy to a solution is not known;
 - in which it is not even known that there is a solution.
 - Arun would probably state that ARPA-E is interested in research on energy problems
 - What are the limits for energy storage with minimum volume and mass?
 - What problems do we have in our community?
 - How close can we approach the perfect thermal insulator?
 - What are upper and lower limits to the thermal conductivity of a polymer?
 - How can we implement a solid-state heat switch?

Technology pull and Pasteur's quadrant

Stokes, 1997

Potential for advancing understanding

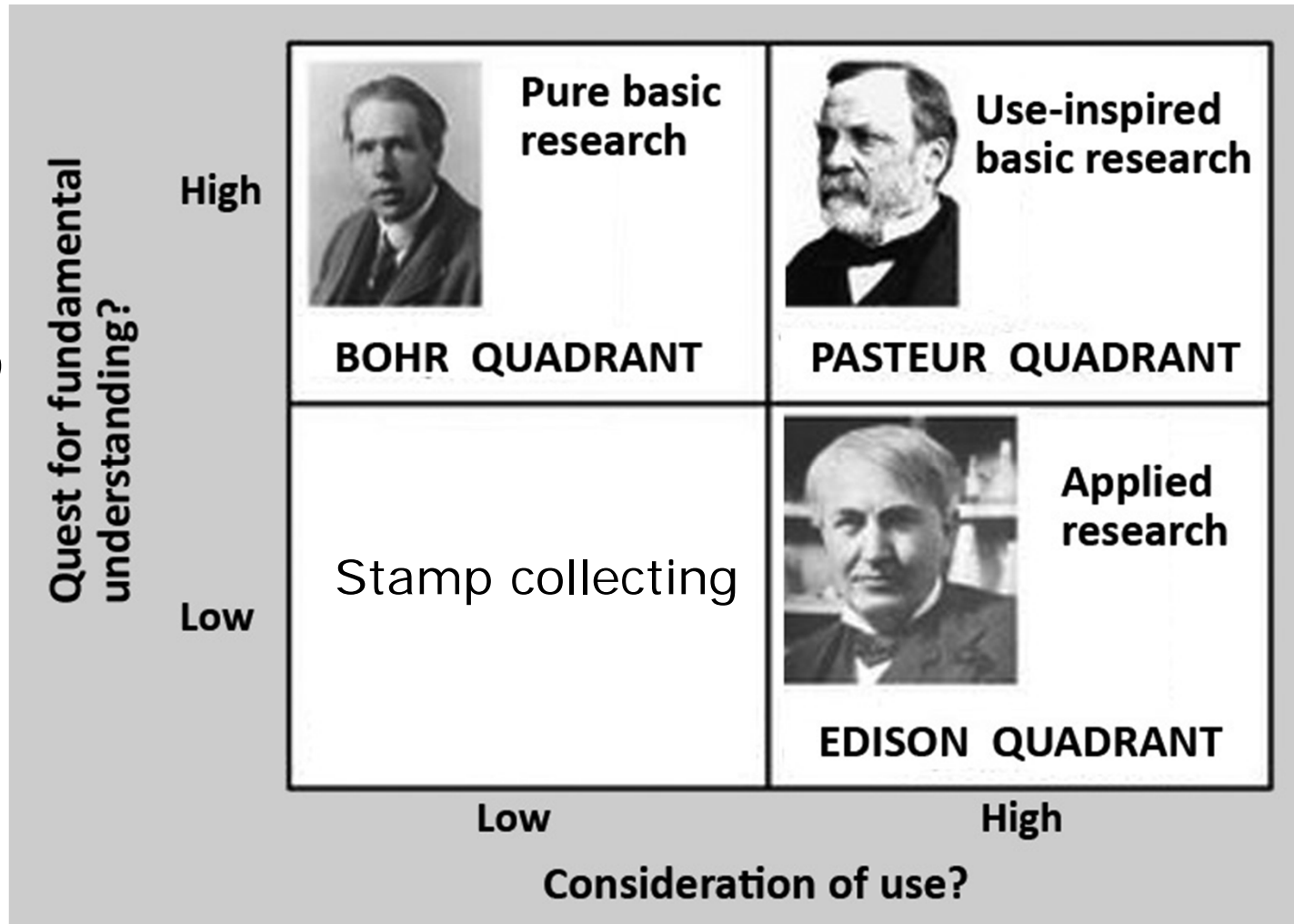

Potential for creating something useful

For thermal transport: Ken's quadrant

Potential for advancing understanding

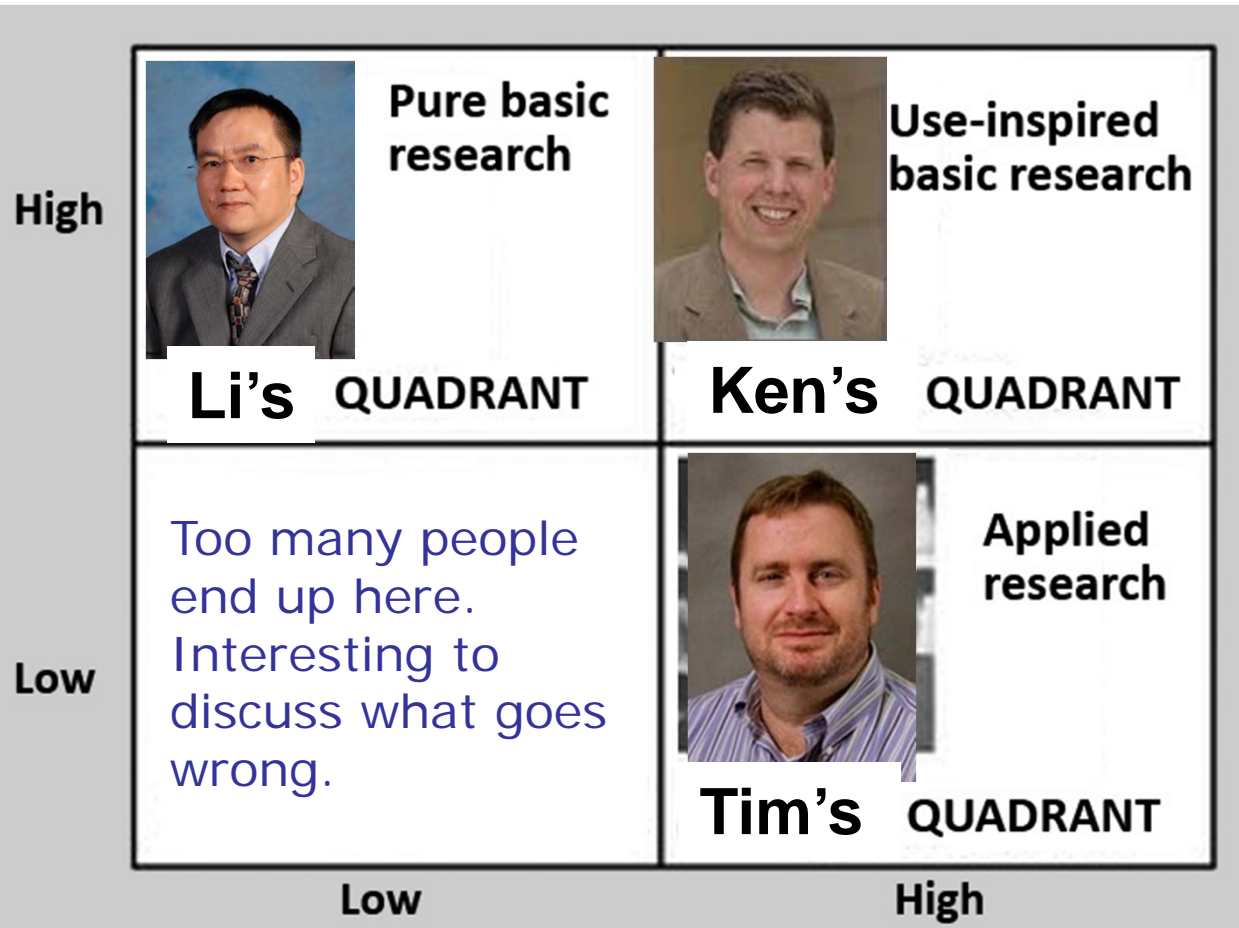

Potential for creating something useful

Assemble interfaces by transfer-printing

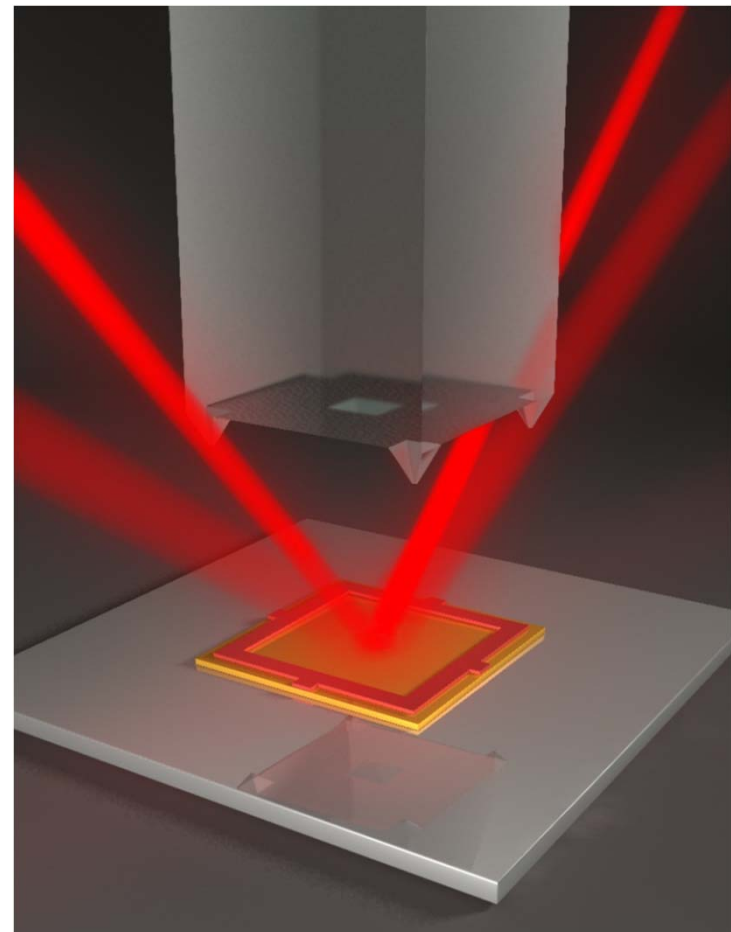
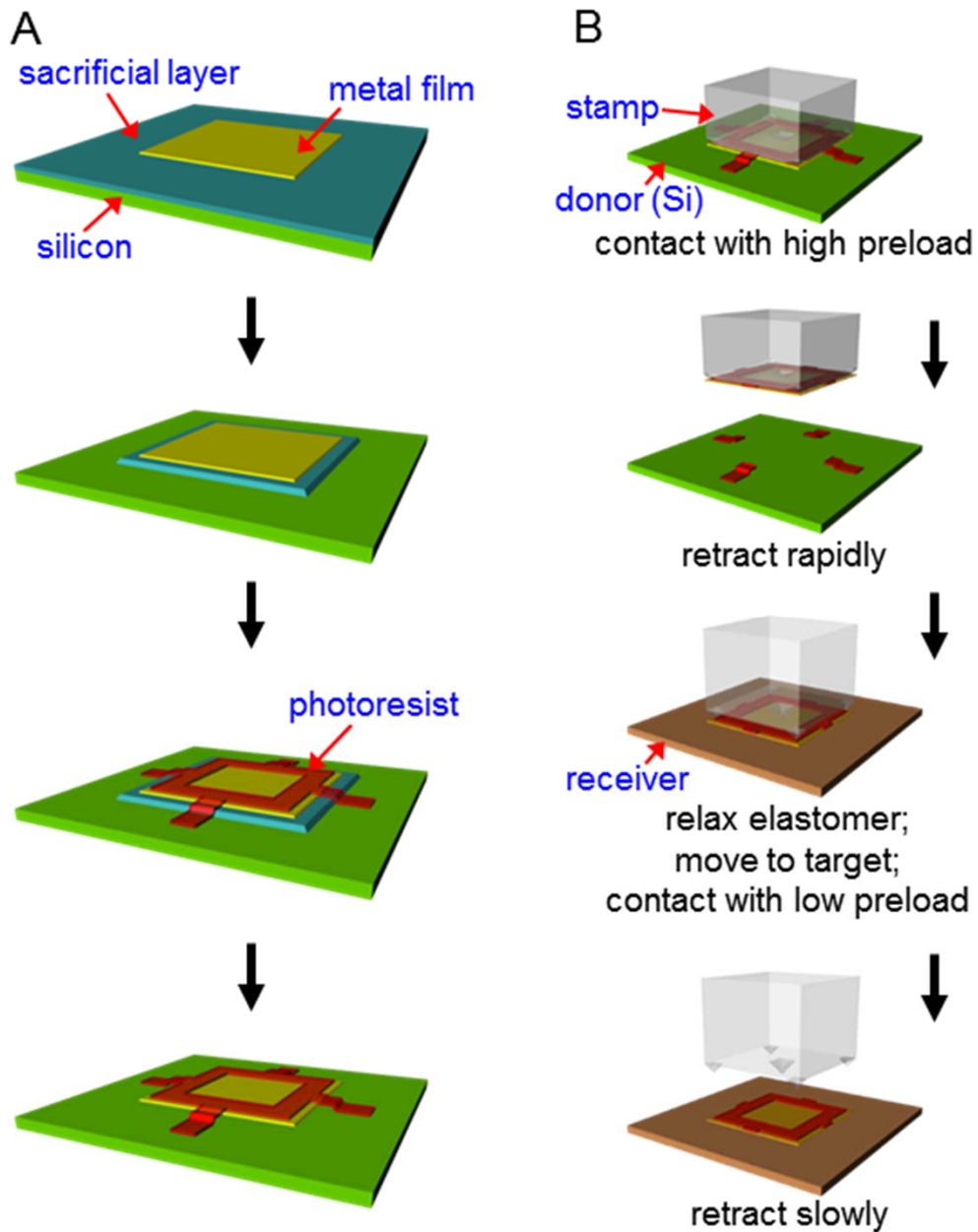

Possible mechanisms for heat transfer at an interface between two elastically stiff solids (Persson 2010)

(a) near-field electromagnetic radiation

(b) gas conduction

(c) conduction through H₂O liquid bridges

(d) conduction across true area of contact

